

ALUMINIUM CNC

Lasting Quality - A process guarantee that the raw material in all aluminum parts retains its purity and integrity, even to an atomic level.

Scientific tests and studies have proven the far superior strength of components manufactured with **CNC Machining** as opposed to the traditional molding process.

CNC machining aligns the aluminum unidirectionally, ensuring it remains 100% compact, and thus much more resistant to **impact, fatigue and corrosion.**

structure
ALUMINIUM INJECTION



ROCKWELL HARDNESS TEST

INJECTION AL 40 - 50 HRB

MACHINED AL CNC 81 HRB

Procedure: The Rockwell test determines the hardness by measuring the depth of penetration of an indenter under a large load compared to the penetration made by a pre-load. In these tests it was proven that the CNC component is twice as resistant as the injection molded part.

structure
ALUMINIUM CNC

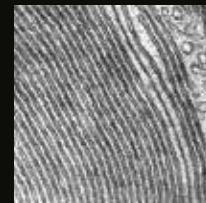

WARRANTY
10
YEARS

A BRAND NEW **GENERATION** AWNINGS & PERGOLAS

by **nevaluz**



SAHARA  **DAKELDROPARM**

NEW GENERATION AWNINGS

The DAKEL drop arm awning is elegant and sophisticated, inspired by modern architectural trends and is manufactured utilising the latest generation of industrial CNC technology. It has a high level of wind resistance in accordance with the UNE EN 13561 standard.

This awning is designed to create a perfect balance between aesthetics appeal and super durability. Versatility is achieved with a choice of either straight or curved arms, and available in numerous combinations of colours, finishes and fabrics, which means it can be adapted to fit in with existing architectural elements. This versatility is further enhanced by its 180° tilt, and the fact that it can be adapted to fit almost anywhere (roof, wall or recess), setting a new standard for fold arm awnings.



COMPONENTS MACHINED ALUMINIUM

Due to CNC Machining, the resistance and quality of the components provide a level of structural strength that is unique in the industry, combined with the appeal of an integrated minimalist design.



ARMS STRAIGHT AND CURVED

The Dakel awning has two tensioned-arm options, allowing it to adapt to any installation requirement, for a window, balcony or façade.

COMPACT DESIGN

The aesthetics of the Dakel awning is symmetrical and integrated, thanks to its geometrically balanced profiles that result in a neat, minimalist look, without visual distraction by unsightly technical components.



VERSATILITY

Installation to recess, wall or roof, vertical opening up to 180° to completely shield from the sun, a multitude of finishes, allows it to be adapted to fit almost any space. This makes DAKEL the ideal solution for so many otherwise challenging situations.

TECHNICAL DETAILS

OPENING

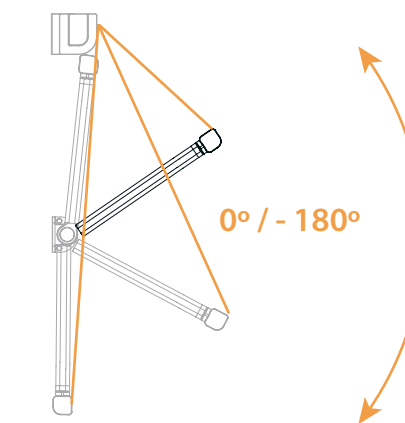

INSTALLATION

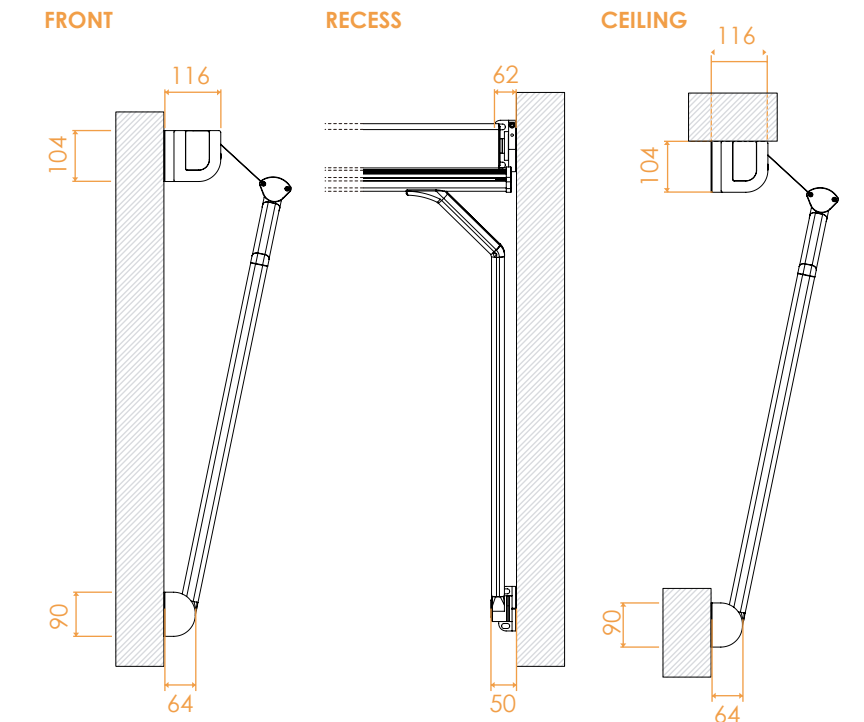

PROFILES

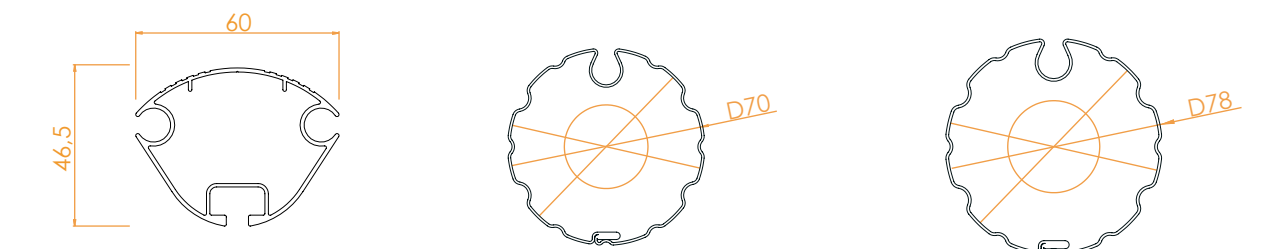

EXAMPLE OF COLOUR COMBINATIONS





WARRANTY
10
YEARS

A BRAND NEW **GENERATION** AWNINGS & PERGOLAS

by **nevaluz**

SAHARA  DAKELPUNTO RECTO

LASTING QUALITY
UNALTERED ALUMINUM